

BALANCING SPRING ASSEMBLY

1. Turn both closing and latching speed adjustment screws two (2) complete turns counterclockwise so that there is no resistance from the hydraulic system.
2. Rotate the closer pivot shaft back and forth from center using an old center pivot arm or wrench. The pivot will be sloppy with no spring resistance in one direction or the other.
3. Turn the pivot in the direction of no resistance until the spring starts resisting further movement and let it remain in that position as shown.
4. Insert a 1/4" extra long allen key through the opening in the preload plug and engage the socket head cap screw inside the stack tube. (See illustration) Turn the hex key clockwise or counterclockwise until the pivot starts to move toward the centerline. (Note: One direction will cause the pivot and wrench to move toward the centerline; the other direction will move the pivot further from center.) Continue to turn allen key in proper direction until pivot is brought back to the centerline and the point of minimum "play" is reached. (Note: If the allen key is turned too far the shaft will become "sloppy" in the other direction.)

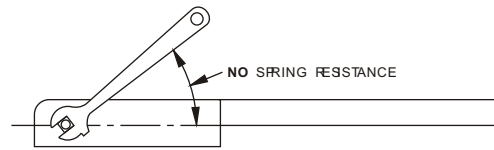

CAUTION

DO NOT UNSCREW PRE-LOAD PLUG. SPRING IS HELD UNDER GREAT PRESSURE.

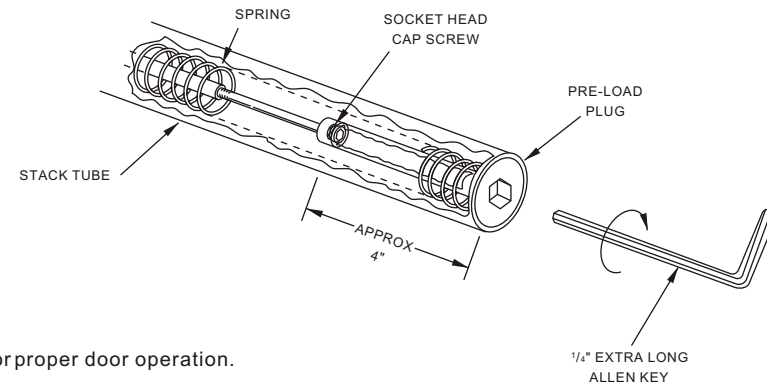

5. Install closer assembly and hand door. Re-adjust closing and latching speeds for proper door operation. (See page 3)

NULLIFYING HOLD OPEN FEATURE (ON EXISTING INSTALLATION)

1. Remove closer from header / transom bar. Place closer pivot side down on working surface. **DO NOT remove hold open block** because it is also used as a guide for the rack.
2. Rotate shaft out of hold open.
3. Use a large flat blade screwdriver (see illustration) as a wedge to keep the hold open slide from turning.
4. While holding hold open slide with screwdriver, tighten the hold open nut with 1/2" open end wrench until cam roller axle is completely inside of hold open block. Hold open is now nullified.

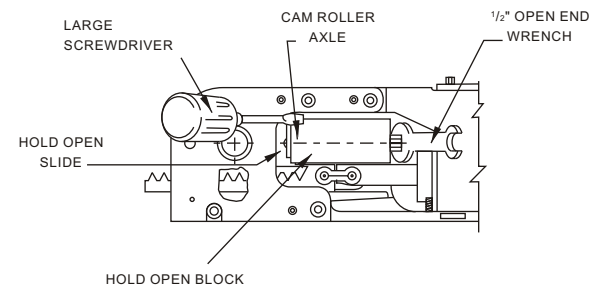

5. a. Mount closer into header or transom. Rotate closer shaft 105° (if closer had a 105° cam) or 120° (if closer had a 90° cam)

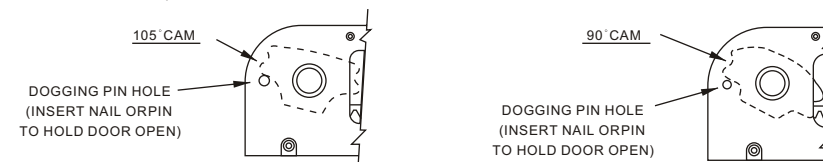

- b. For door installation, insert a suitable 5/32" diameter hard pin or nail through 3/16" hole in closer base plate. The pin should be inserted at least 1-1/2" into the closer.

CAUTION: Be sure to remove pin before trying to operate closer. To remove pin, open closer from dogged position to remove spring force from pin. Remove pin and release door.

**THE CONCEALED OVERHEAD CLOSER
INSTALLATION & ADJUSTMENTS
NEW INSTALLATIONS**

NOTE: FOR REPLACEMENT INSTRUCTIONS SEE NEXT PAGE.

1. Installing Closer in Mounting Tray

Place closer on sawhorse or Truck bed with pivot shaft up.

- a. Position mounting tray on closer as shown in illustration, making sure hole in tray fits properly around shaft bearing. Attach mounting tray to closer using #10 TAPTITE screws in hole nearest pivot shaft.

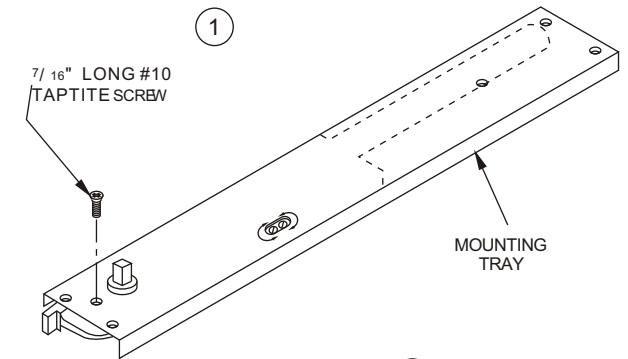

DO NOT DRILL CLOSER.

- b. Slip galvanized steel retainer strap under closer stack tube with tab down, as shown, and line-up with mounting hole in tray.
- c. Insert anchor screw through mounting plate and leg of strap. Fold remaining portion of strap around stack tube and place tab over anchor screw.
- d. Place angle clamp over anchor screw, as shown, and tighten securely.

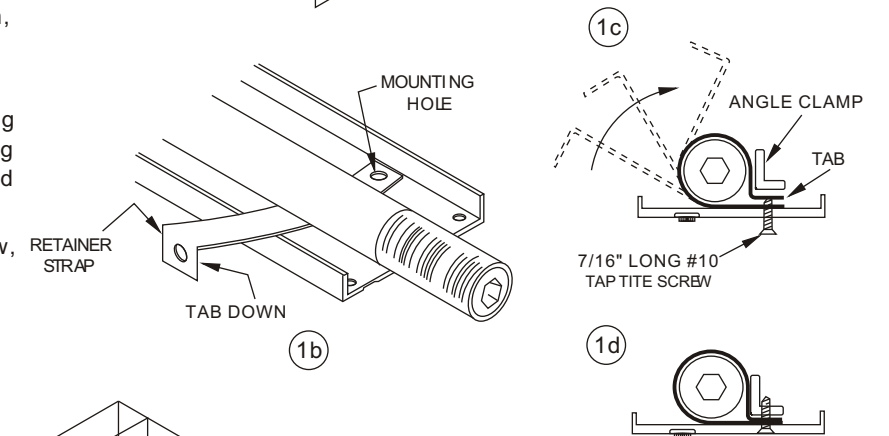

2. Installing Closer in Frame

Insert closer into cut-out in header or transom bar, rack end first. Check position of factory installed steel tabs for screw hole alignment and adjust if necessary by tapping with mallet.

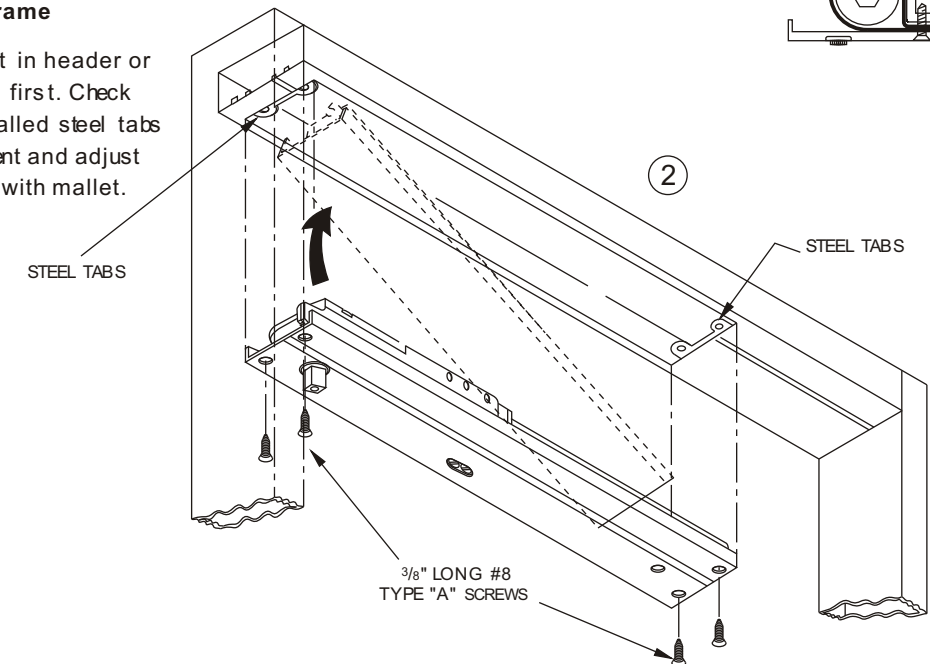

**THE CONCEALED OVERHEAD CLOSER
REPLACEMENT INSTRUCTIONS
ALL (OLDSTYLEFRAMES)**

IMPORTANT INFORMATION

The mounting method used for the concealed closer in old style frames is somewhat different than that used for the M-2 concealed closer. When replacing an M-2 with a HUSKY, modification of the plate and installation of a mounting retainer strap will be required. Please follow these instructions closely.

1. Modification of Mounting Plate

- File two notches in mounting plate adjusting slot to provide access to adjusting screws. Notches are **always away** from two mounting screw holes. See illustration 1.
- Drill $\frac{13}{64}$ " diameter hole in end of mounting plate apposite closer shaft hole, and countersink for #10 screw. Use template below for proper hole location. (**Note: template is always placed on mounting plate surface containing weathering.**)

DO NOT Drill Closer.

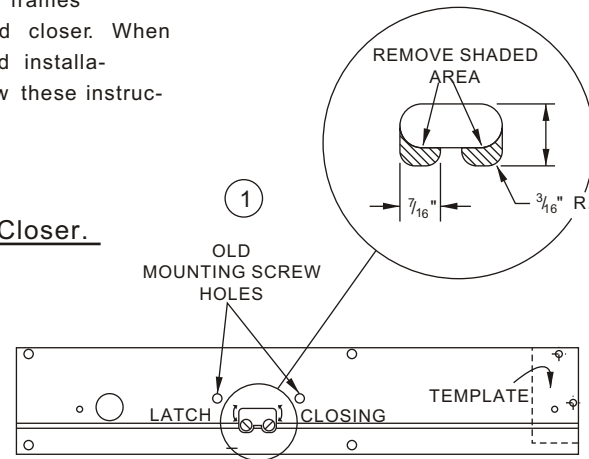

**DO NOT DRILL CLOSER
DRILLING CLOSER WILL VOID
WARRANTY**

PLACE THIS LINE FLUSH WITH SIDE OF MOUNTING PLATE IN EXISTING SPANLINE FRAMING.

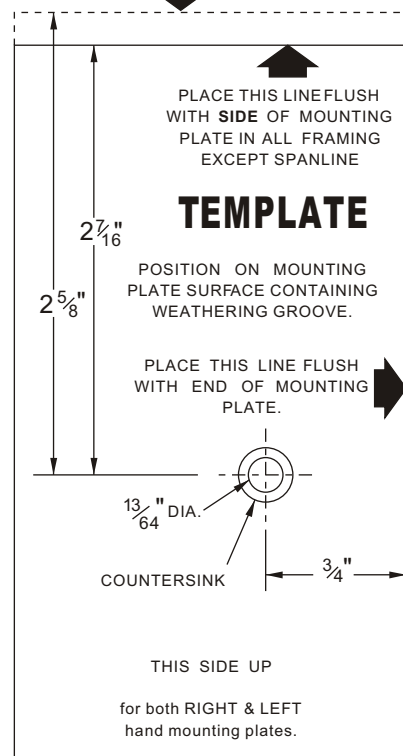

2. Attaching Closer to Mounting Plate

- Fasten closer to mounting plate using **only** the screw hole nearest the pivot shaft. The two remaining mounting screw holes will **not** be used.
- Slip spring steel retainer strap under closer stack tube with tab down, as shown, and line-up with previously drilled mounting hole.
- Insert anchor screw through mounting plate and leg of strap. Fold remaining portion of strap around stack tube and place tab over anchor screw.
- Place angle clamp over anchor screw, as shown, and tighten securely.

2A

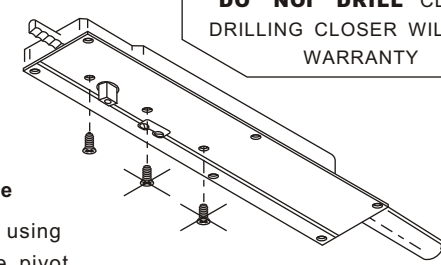

2B

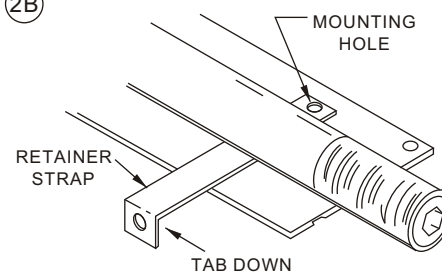

2C

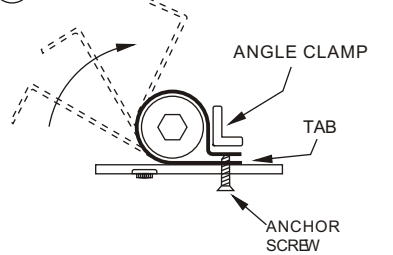

2D

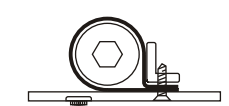

3. Install Closer in Frame

**ADJUSTMENT INSTRUCTIONS
THE CONCEALED OVERHEAD CLOSER**

The concealed closer has two-speed closing control to prevent the door from slamming against the stop on single acting applications, and to prevent over-swing on double acting applications. Through the first 80 degrees of the closing cycle, the door should be kept at a moderate speed to prevent "heel bumping" as someone enters through an out-swing door. The last 10 degrees of the closing cycle are the latching or cushion control and should be set as follows:

- Further reduce the closing speed bringing the door to a soft firm close.
- Increasing the closing speed to assure positive engagement of latch locks or panic devices.

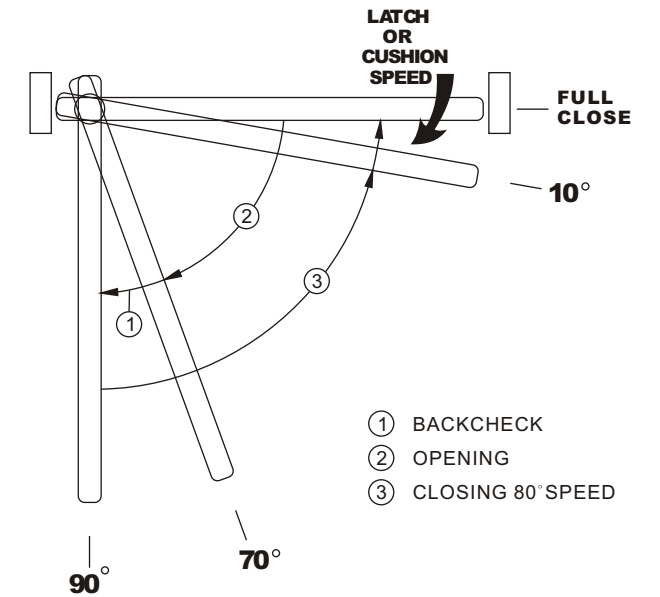

The complete closing cycle, from 90 degrees open to full closed should take approximately 4 to 8 seconds. If adjustments are required, proceed as follows:

Closing Speed Adjustment

Turn closing speed valve counter-clockwise to increase door closing speed, or clockwise to reduce door closing speed.

Latching Speed

Turn latching speed valve counter-clockwise to increase door latching speed or clockwise to reduce door latching speed.

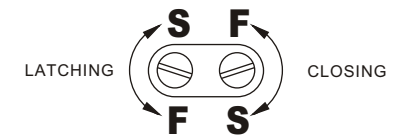

Note: Adjusting closing and latching speeds for one direction of door operation automatically sets speeds for both directions.

Spring power Adjustment

The spring power of the closer is not adjustable. Recommends that if more power is required the next size closer should be used.

Balancing Spring Assembly (Not required on new closers)

NULLIFYING HOLD OPEN FEATURE

See back page for balancing and nullifying hold open instructions.