

FOR DEAD STOP ARM INSTALLATION INSTRUCTION

CLOSER MOUNTED ON DOOR ON PUSH SIDE

1. Before installation, (parallel arm), turn Back Check selector valve (found on the opposite side of closer) ALL THE WAY IN (CLOCKWISE).
2. Mount closer on door as dimensions shown. Tube end toward latch. If pivots are used, locate closer and parallel bracket from CENTERLINE OF PIVOT.
3. Place open end wrench on bottom shaft and turn toward hinge jamb about 30°, and then place main arm on top shaft, insert arm screw into top of shaft and tighten.
4. Attach parallel bracket on frame as dimensions shown.
5. Attach rod and shoe to parallel bracket as shown.
6. Insert rod in forearm, and then insert main arm to closer parallel to door. Then insert forearm set screw and tighten.
(IF HOLD OPEN ARM IS USED, THE NUT IS ON THE TOP FOR RH DOOR AND BOTTOM FOR LH DOOR)

REGULATION:

A 'Normal' closing time from 90° open position to door stop position is 4-6 secs, evenly divided between main swing speed and latch swing speed. Use socket key (furnished) to adjust speed. To slow main speed of door, turn regulating screw nearest shaft clockwise. To slow latch speed, turn regulating screw nearest hinge clockwise.

BACK CHECK

To increase back-check force, turn regulating screw nearest hinge clockwise. DO NOT USE ABRUPT BACK-CHECK OR EXPECT DOOR CLOSER TO ACT AS A DOOR STOP.

COVER

Place insert in proper cutout, then push cover against door frame. Tighten both cover screw securely.

HOLD OPEN ADJUSTMENT

Loose adjusting nut, open door to desired hold open position and tighten nut.

Do not permit door to swing while hold open is setting.

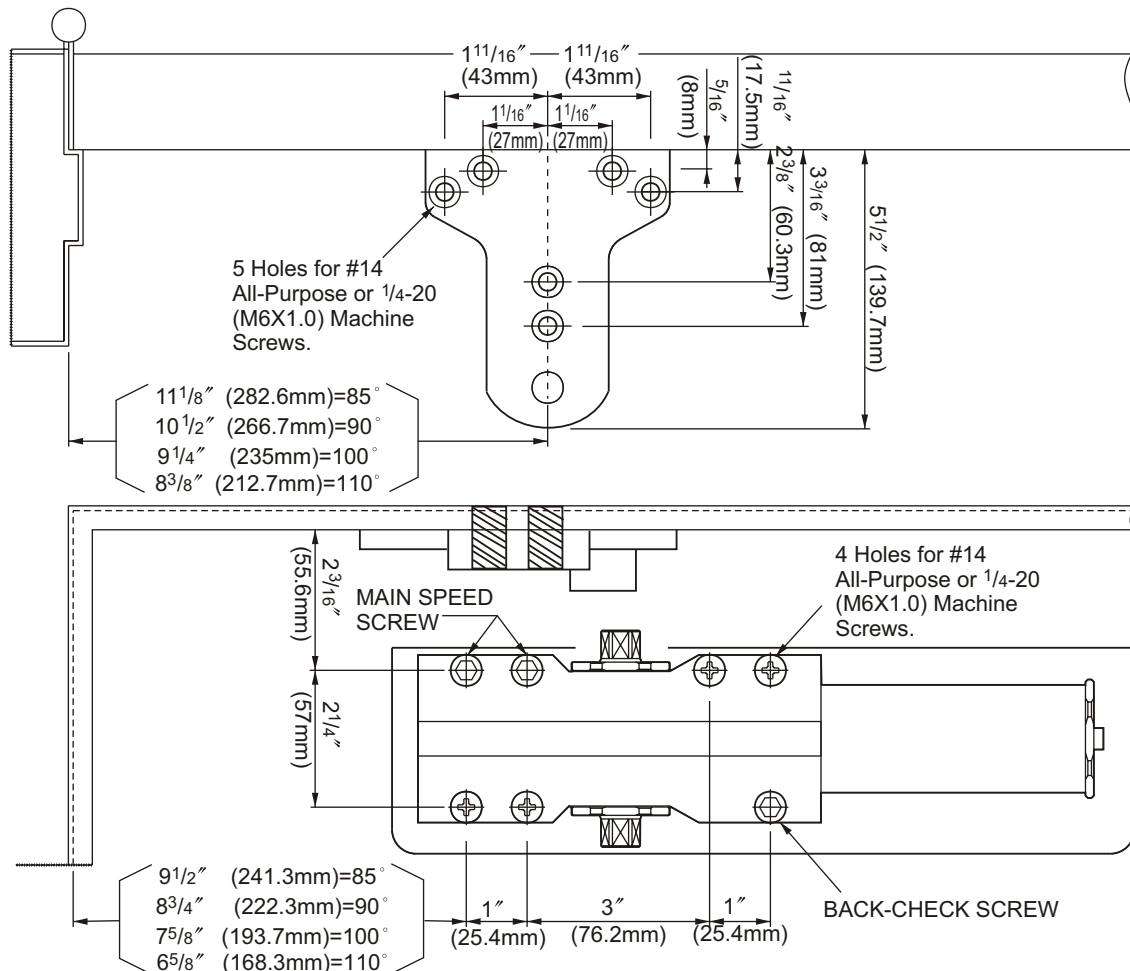
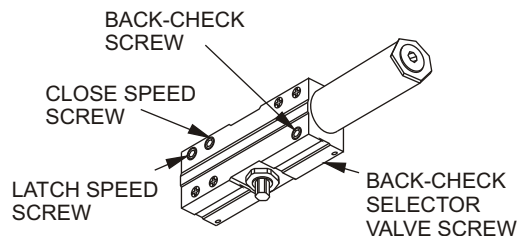
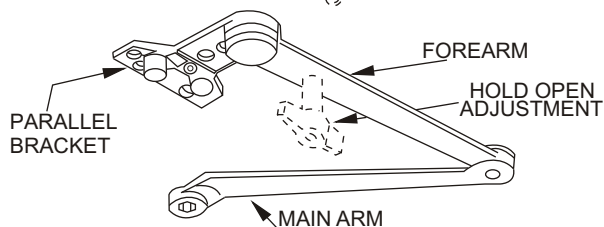
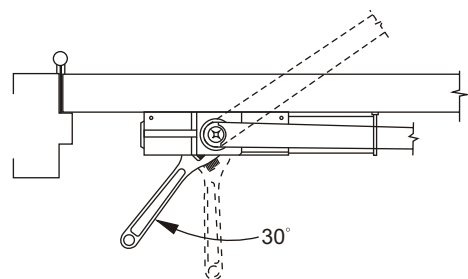

FOR HOLD OPEN ARM INSTALLATION INSTRUCTION

CLOSER MOUNTED ON DOOR ON PUSH SIDE

1. Before installation, (parallel arm), turn Back Check selector valve (found on the opposite side of closer) ALL THE WAY IN (CLOCKWISE).
2. Mount closer on door as dimensions shown. Tube end toward latch. If pivots are used, locate closer and parallel bracket from CENTERLINE OF PIVOT.
3. Place open end wrench on bottom shaft and turn toward hinge jamb about 30°, and then place main arm on top shaft, insert arm screw into top of shaft and tighten.
4. Attach parallel bracket on frame as dimensions shown.
5. Attach rod and shoe to parallel bracket as shown.
6. Insert rod in forearm, and then insert main arm to closer parallel to door. Then insert forearm set screw and tighten.
(IF HOLD OPEN ARM IS USED, THE NUT IS ON THE TOP FOR RH DOOR AND BOTTOM FOR LH DOOR)

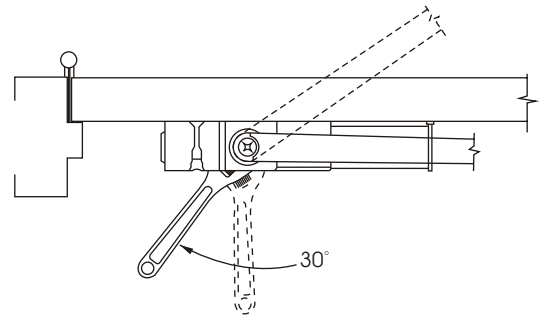

REGULATION:

A 'Normal' closing time from 90° open position to door stop position is 4-6 secs, evenly divided between main swing speed and latch swing speed. Use socket key (furnished) to adjust speed. To slow main speed of door, turn regulating screw nearest shaft clockwise. To slow latch speed, turn regulating screw nearest hinge clockwise.

BACK CHECK

To increase back-check force, turn regulating screw nearest cylinder clockwise. DO NOT USE ABRUPT BACK-CHECK OR EXPECT DOOR CLOSER TO ACT AS A DOOR STOP.

COVER

Place insert in proper cutout, then push cover against door frame. Tighten both cover screw securely.

HOLD OPEN ADJUSTMENT

Loose adjusting nut, open door to desired hold open position and tighten nut. Do not permit door to swing while hold open is setting.

