

DOOR CLOSER

PARALLEL ARM INSTALLATION CLOSER MOUNTED ON DOOR ON PUSH SIDE

THIS TEMPLATE COVERS REGULAR ARM INSTALLATIONS TO 180° OPENINGS.
Parallel bracket accessory required and must be ordered extra.

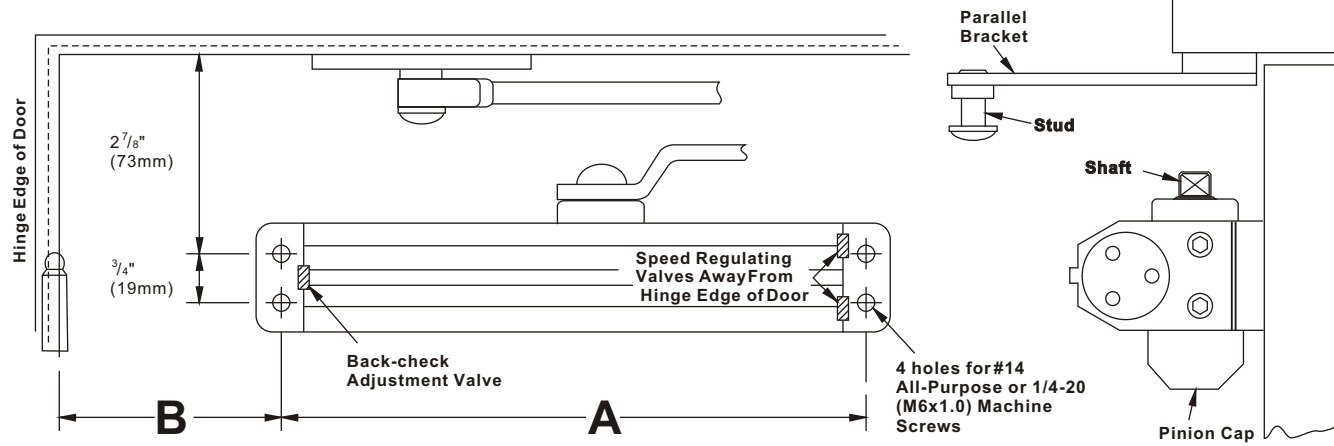

LEFT HAND DOOR ILLUSTRATED. Same dimensions apply for Right Hand Door measured from hinge edge.

SIZE	MAXIMUM DOOR WIDTH		
	INTERIOR DOOR SIZE	EXTERIOR DOOR SIZE SWING OUT	SWING IN
3	3BC 40\"(1016mm)	28\"(711mm)	32\"(813mm)
4	4BC 48\"(1219mm)	40\"(1016mm)	38\"(965mm)
5	5BC 52\"(1321mm)	48\"(1219mm)	40\"(1016mm)

A	FOR OPENING TO 120°		FOR OPENING 180° ~ 120°	
	B	C	B	C
9 1/16\"(230mm)	7 15/16\"(202mm)	8 5/8\"(219mm)	6 7/16\"(164mm)	7 1/8\"(181mm)

NO HOLD OPEN INSTALLATION INSTRUCTION

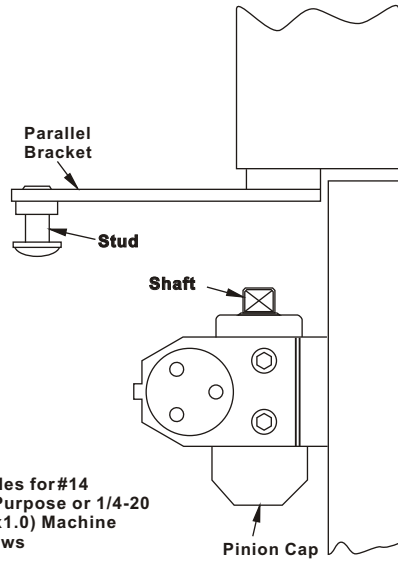

INSTALLATION INSTRUCTIONS

- Select degree of opening and use dimensions shown in above template to mark four holes on door for closer and four holes on frame for parallel bracket.
- Drill pilot holes in door and frame for #14 wood screws or drill and tape for 1/4-20 (M6X1.0) machine screws.
- Mount closer on door WITH SPEED REGULATING SCREW AWAY FROM HINGE EDGE.
- Attach parallel bracket to door stop as illustrated.
- Using a wrench on the square shaft on bottom of closer, rotate shaft approximately 45° toward hinge edge of door. Hold and place main arm on shaft on top of closer at proper index mark as illustrated. FOR LEFT HAND DOOR No. 3 (illustration "A") FOR RIGHT HAND DOOR No. 2 (illustration "B"). Tighten arm screw with lockwasher securely.
- Remove the arm shoe from the forearm (arm shoe is not used in this application) and place forearm on parallel bracket stud and tighten screw securely.
- Adjust length of forearm so when it is attached to main arm, the main arm will be slightly away from parallel with closed door, and assemble at elbow then tighten locknut.

ADJUSTMENT INSTRUCTIONS

CLOSING POWER—As per "Spring Tension Chart" select the correct number of turns for spring adjustment nut that corresponds with the installation. Using 5/32\"(4mm) allen key, turn adjustment nut full 360° clockwise turns to desired setting.

SPEED—Door closing and latching speeds are controlled by #1, #2 speed regulating screw separately.
A. Clockwise turns slow the speed. B. Counterclockwise turns increase the speed.

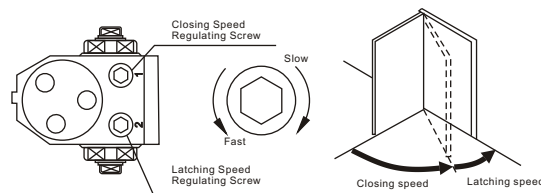

BACK-CHECK ADJUSTMENT—is controlled by the adjustment valve, BACK-CHECK is now set for soft action. To INCREASE Back-check action turn valve CLOCKWISE. To DECREASE, or to TURN OFF Backcheck action turn valve COUNTER CLOCKWISE.

POSITION OF ARMS AND INDEX SETTINGS

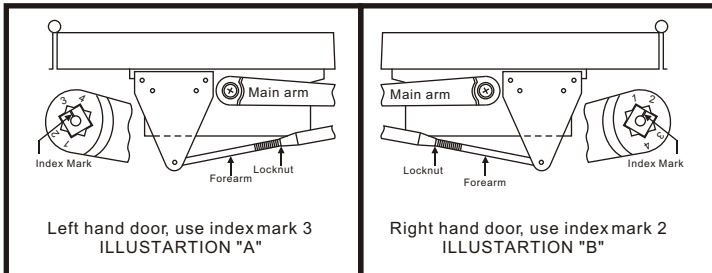

STANDARD INSTALLATION CLOSER MOUNTED ON DOOR ON PULL SIDE

THIS TEMPLATE COVERS REGULAR ARM INSTALLATIONS TO 180° OPENINGS.

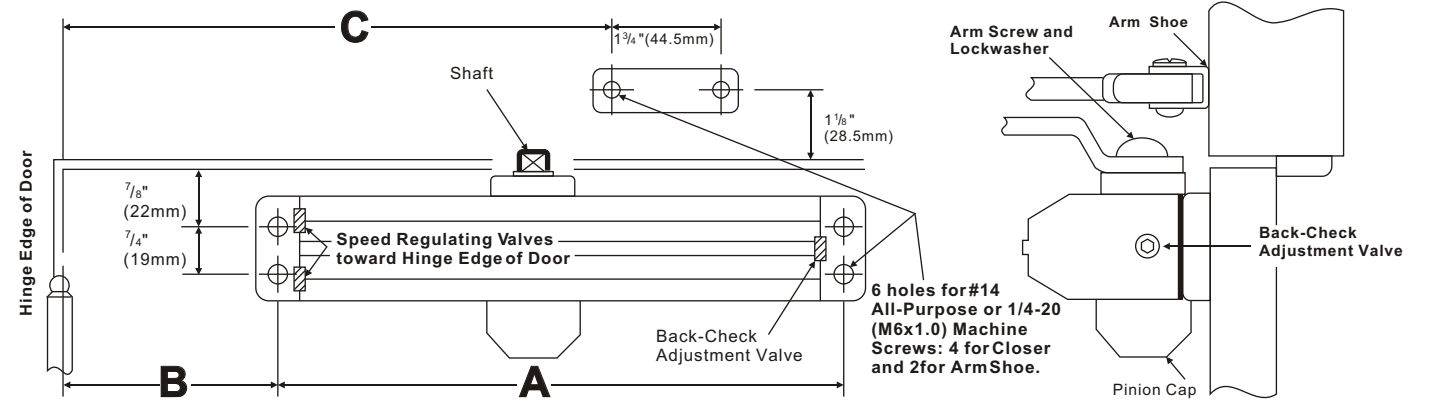

RIGHT HAND DOOR ILLUSTRATED. Same dimensions apply for Left hand door measured from hinge edge.

A	FOR OPENING TO 120°		FOR OPENING 120° ~ 180°	
	B	C	B	C
9 1/16\"(230mm)	5 1/4\"(149mm)	12 1/4\"(306mm)	3 1/2\"(82.5mm)	8 1/2\"(225mm)

SIZE	MAXIMUM DOOR WIDTH		
	INTERIOR DOOR SIZE	EXTERIOR DOOR SIZE SWING OUT	SWING IN
3	3BC 40\"(1016mm)	34\"(864mm)	32\"(813mm)
4	4BC 48\"(1219mm)	40\"(1016mm)	34\"(864mm)
5	5BC 52\"(1321mm)	48\"(1219mm)	40\"(1016mm)

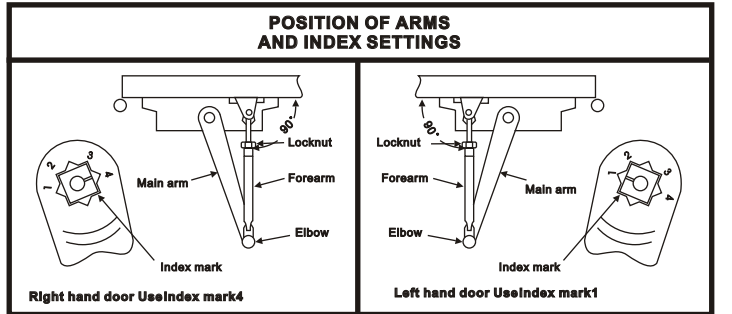

TOP JAMB INSTALLATION CLOSER MOUNTED TOP JAMB ON PUSH SIDE OF DOOR

THIS TEMPLATE COVERS REGULAR ARM INSTALLATIONS TO 180° OPENINGS.
Reveals of 2 3/4\"(70mm) to 5 1/2\"(140mm) require "Top Jamb" Forearm Extender Accessory and must be ordered extra.

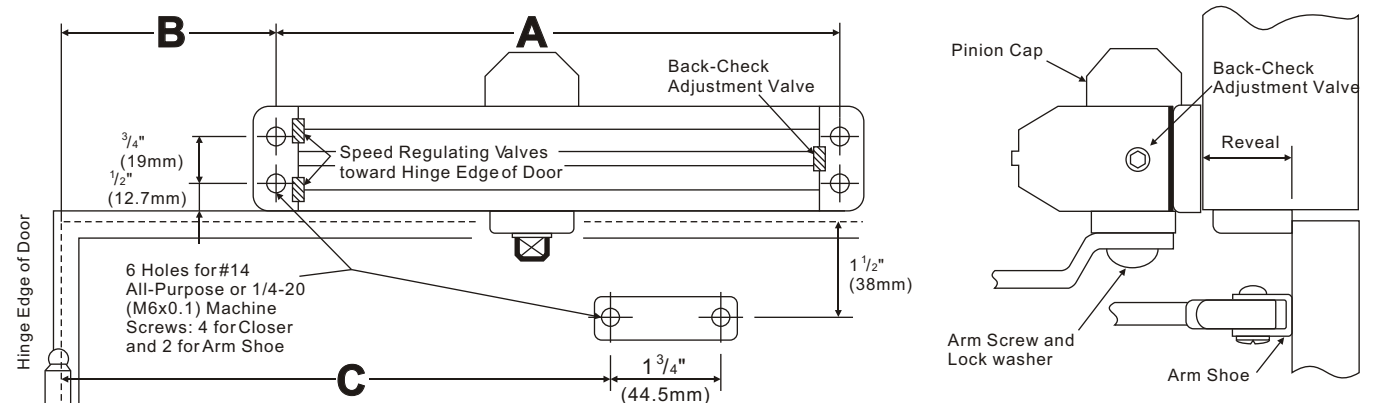

LEFT HAND DOOR ILLUSTRATED. Same dimensions apply for Left hand door measured from hinge edge.

A	FOR OPENING TO 120°		FOR OPENING 120° ~ 180°	
	B	C	B	C
9 1/16\"(230mm)	5 1/4\"(148mm)	12\"(305mm)	4 1/4\"(105mm)	10 1/4\"(262mm)

SIZE	MAXIMUM DOOR WIDTH		
	INTERIOR DOOR SIZE	EXTERIOR DOOR SIZE SWING OUT	SWING IN
3	3BC 40\"(1016mm)	34\"(864mm)	32\"(813mm)
4	4BC 48\"(1219mm)	40\"(1016mm)	34\"(864mm)
5	5BC 52\"(1321mm)	48\"(1219mm)	40\"(1016mm)

